



## DEPARTMENT OF THE ARMY

THE INSTITUTE OF HERALDRY  
9325 GUNSTON ROAD, ROOM S113  
FORT BELVOIR, VIRGINIA 22060-5579

SAAA-IHS

17 November 2020

MEMORANDUM FOR Commander, 470th Quartermaster Company

SUBJECT: Beret Flash and Background Trimming for the 470th Quartermaster Company

1. The following heraldic items are authorized for the 470th Quartermaster Company:

a. Beret Flash and Background Trimming. The descriptions of the designs are as follows:

### **BERET FLASH**

A shield-shaped embroidered item with a semicircular base 2 1/4 inches (5.72 cm) in height by 1 7/8 inches (4.76 cm) in width overall, consisting of a buff background with three contiguous diagonal lines from upper left corner to lower right corner, each 1/8 inch (.32 cm) in width. The diagonal lines from top to bottom are orange, ultramarine blue, and orange. The item is edged with a 1/8 inch (.32 cm) ultramarine blue outer border and a 1/8 inch (.32 cm) white inner border.

### **BACKGROUND TRIMMING**

An oval shaped embroidered item 1 3/8 inches (3.49 cm) in height by 2 1/4 inches (5.72 cm) in width overall, consisting of a buff background with three contiguous diagonal lines from upper left corner to lower right corner, each 1/8 inch (.32 cm) in width. The diagonal lines from top to bottom are orange, ultramarine blue, and orange. The item is edged with a 1/8 inch (.32 cm) ultramarine blue outer border and a 1/8 inch (.32 cm) white inner border.

b. This authorization does not grant exclusive use of the above colors and pattern design for the 470th Quartermaster Company.

2. Enclosed for use in procurement of the items are:

a. TIOH Drawing No. A-4-329 and A-6-356.

SAAA-IHS

SUBJECT: Beret Flash and Background Trimming for the 470th Quartermaster Company

- b. Digital artwork in color.
  - c. A list of certified manufactures and procedures for local procurement of insignia.
3. This authorization is IAW AR 670-1. A copy of this memorandum will become part of your permanent organizational history files.
4. Your point of contact for this action is the Heraldic Services and Support Division at (571) 515-0324.

Encls



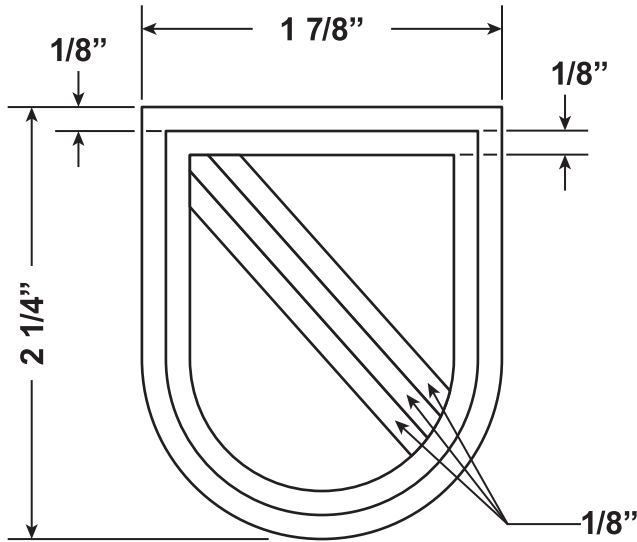

MUGNO.CH MUGNO.CHARLE  
ARLES.V.102 S.V.1020723374  
0723374 2020.11.17  
11:57:01 -05'00'  
CHARLES V. MUGNO  
Director

**REVISIONS**



**DESIGNED FOR  
OVEREDGE STITCHING**



-  **White Cable No. 67101**
-  **Orange Cable No. 67110**
-  **Ultramarine Blue Cable No. 67118**
-  **Buff Cable No. 67135**

<b>PREPARED</b>	<b>AFW</b>	<b>THE INSTITUTE OF HERALDRY, DEPARTMENT OF THE ARMY</b>	
<b>EXAMINED</b>	<i>Sao</i>	9325 GUNSTON RD, RM S-113 FORT BELVOIR, VA 22060-5579	
<b>HDD CHIEF</b>	<b>AWW</b>	<b>BERET FLASH</b>	
<b>APPROVED</b>	MUGNO.CHARL	<b>470TH QUARTERMASTER COMPANY</b>	
	MUGNO.CHARLES.V. 1020723374 ES.V.102072337 2020.11.17 11:57:20 4 -05'00'		
	<b>CHARLES V. MUGNO, DIRECTOR</b>	<b>SCALE</b> <b>FULL</b>	<b>DISTRIBUTION A.</b> APPROVED FOR PUBLIC RELEASE
<b>MATERIALS: TO BE MANUFACTURED IN ACCORDANCE WITH MIL-DTL-14652</b>		<b>DATE:</b>	<b>17 NOVEMBER 2020</b>



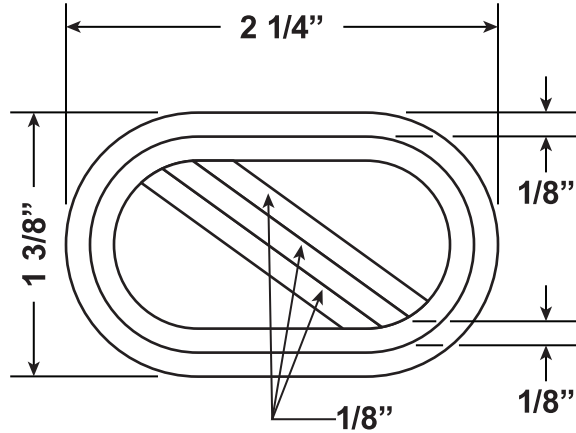

**A-4-329**

**REVISIONS**

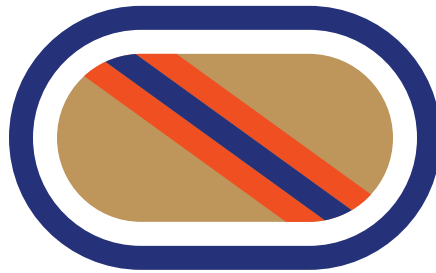

**DESIGNED FOR  
OVEREDGE STITCHING**



-  **White Cable No. 67101**
-  **Orange Cable No. 67110**
-  **Ultramarine Blue Cable No. 67118**
-  **Buff Cable No. 67135**

<b>PREPARED</b>	<b>AFW</b>	<b>THE INSTITUTE OF HERALDRY, DEPARTMENT OF THE ARMY</b> 9325 GUNSTON RD, RM S-113 FORT BELVOIR, VA 22060-5579
<b>EXAMINED</b>	<i>Sao</i>	
<b>HDD CHIEF</b>	<b>AWW</b>	<b>BACKGROUND TRIMMING</b> <b>470TH QUARTERMASTER</b> <b>COMPANY</b>
<b>APPROVED</b>	MUGNO.CHARLES.V. MUGNO.CHARLE 1020723374 S.V.1020723374 2020.11.17 11:57:32 -05'00'	
<b>CHARLES V. MUGNO, DIRECTOR</b>		SCALE <b>FULL</b> DISTRIBUTION A. APPROVED FOR PUBLIC RELEASE
<b>MATERIALS: TO BE MANUFACTURED IN ACCORDANCE WITH MIL-DTL-14652</b>		DATE: <b>17 NOVEMBER 2020</b>
		<b>A-6-356</b>



<https://tioh.army.mil>  
[usarmy.belvoir.hqda.mbx.tioh-webmaster@mail.mil](mailto:usarmy.belvoir.hqda.mbx.tioh-webmaster@mail.mil)  
8 August 2019

## LOCAL PROCUREMENT PROCEDURES OF INSIGNIA

--

1. Authorization for local procurement of insignia as specified in paragraph 3 below is contained in AR 710-2 and AR 670-1. Distinctive Unit Insignia (DUI) and regimental collar insignia (RCI) are locally procured. In addition, authorized shoulder sleeve insignia (SSI) may be locally procured until it is centrally procured and stocked through the Soldier Systems Directorate, Philadelphia. After shoulder sleeve insignia has been stocked by Philadelphia, local purchase is unauthorized.

2. After an insignia item has been approved by The Institute of Heraldry (TIOH), one of the following actions will be taken based upon the type of funds used for procurement:

a. Use of Appropriated Funds. Requisitions will be submitted through supply channels and purchased by local command servicing procurement officers for Active Army and Army Reserve units and by the USP&FO for Army National Guard units. A purchase request for local procurement will be prepared and submitted to the contracting officer in accordance with local procedures. The contracting officer will provide the manufacturer with the official manufacturing drawing for bidding purposes. Upon obtaining an acceptable bid, the contracting officer will advise the selected manufacturer to contact TIOH for loan of government tools to be used in manufacturing metal insignia items. A drawing is not required for RCI.

b. Use of Nonappropriated Funds. AR 670-1 permits use of nonappropriated funds (Unit Fund) for purchase of DUI when appropriated funds are not available. Unit funds may not be used to purchase SSI or RCI. A manufacturer must be selected from the list of manufacturers certified by TIOH for unit fund and other types of nonappropriated purchases, such as group purchases.

3. All insignia must be manufactured by firms certified by TIOH in accordance with AR 672-8. Procurement of insignia from non-certified manufacturers or from foreign or offshore sources is not authorized. Manufacturers who are interested in becoming certified manufacturers will be referred to the Director, The Institute of Heraldry for certification. All invitations for bids or contracts should include a statement that the insignia will be made in accordance with the specifications and tools provided by TIOH.

a. Distinctive Unit and Regimental Collar Insignia. DUI and regimental collar insignia must have the hallmark of the manufacturer stamped on the reverse. In addition, all DUI must have "Made in USA" stamped on the reverse. DUI will be manufactured in accordance with MIL-I-14654(IH). Regimental collar insignia will be

## LOCAL PROCUREMENT PROCEDURES OF INSIGNIA

--

manufactured in accordance with MIL-I-3575 for officers and MIL-I-15665 for enlisted personnel. Purchase request for DUI should include unit designation and the motto contained on the DUI, if applicable. Requests for regimental collar insignia or DUI should include unit designation and the motto contained on the DUI, if applicable. Requests for regimental collar insignia should include the name of the branch and the regimental number. Note: The battalion numerical designation will not be placed on Infantry, Armor, Cavalry, Field Artillery, Air Defense Artillery or Aviation regimental collar insignia. Hubs and/or dies will be loaned to the contractor by TIOH.

b. Shoulder Sleeve Insignia. Shoulder sleeve insignia will be manufactured in accordance with MIL-I-14652. The contractor will be advised that a "cartoon" (pattern) showing the placement and the number of stitches for the SSI may be obtained from TIOH.

c. ROTC Shoulder Loop Insignia. Solicitations for ROTC shoulder loop insignia should indicate that the insignia will be manufactured in accordance with MIL-I-14654(IH) and the contractor will be responsible for making any hubs and dies necessary for manufacturing. The design will be in accordance with the TIOH approved drawing.

d. Beret Flashes, Background Trimmings and ROTC Institutional SSI. The solicitation should indicate the insignia will be manufactured in accordance with MIL-I-14652 from the approved TIOH drawing. A "cartoon" (pattern) is not provided for these items.

4. The manufacturer is required to submit preproduction samples of all insignia to TIOH regardless of whether appropriated or nonappropriated funds are used for procurement. Once samples are approved, TIOH will issue a letter to the manufacturer authorizing manufacture of the insignia item. National Guard regulations currently require that a copy of the letter be forwarded by the manufacturer to the USP&FO prior to completion of the order. This procedure is recommended for inclusion in contracts by Regular Army and US Army Reserve procurement officers to insure that samples have been approved by TIOH.



THE INSTITUTE OF HERALDRY  
 DEPARTMENT OF THE ARMY  
 9325 GUNSTON ROAD, ROOM S113  
 FORT BELVOIR, VIRGINIA 22060-5579  
 571-515-0346

<https://tioh.army.mil>  
[usarmy.belvoir.hqda.mbx.tioh-webmaster@mail.mil](mailto:usarmy.belvoir.hqda.mbx.tioh-webmaster@mail.mil)  
 10 March 2020

### TIOH CERTIFIED MANUFACTURERS

NAME	STREET	LOCATION	HMK	TYPE	PHONE	FAX
A B EMBLEMS/CONRAD	291 MERRIMON AVENUE	WEAVERVILLE, NC 28787	A35	1	828-645-3015	828-658-3581
ACTION EMBROIDERY CORP	1315 WEST BROOKS ST	ONTARIO, CA 91762	A25	1	800-638-7223	909-983-2755
BALLY RIBBON MILLS	23 NORTH SEVENTH ST	BALLY, PA 19503	B22	1d	610-845-2211	610-845-8013
BENDE & SONS, INC	180 AUTUMN ST	PASSAIC, NJ 07055	B26	1d	973-777-8700	973-777-7715
GREAT AMERICAN WEAVING	20 NORTH FRONT STREET	BALLY, PA 19503	G31	1d	610-845-9200	610-845-7147
HALLMARK EMBLEMS INC	2401 TAMPA STREET	TAMPA, FL 33602	H27	1	800-237-2567	813-273-0564
RELIABLE WORLD TRADE CO.	9849 KITTY LANE	OAKLAND, CA 94603	R-30	1c	510-614-2277	510-614-2277
SAYRE ENTERPRISES	324 EAST 32ND STREET	BUENA VISTA, VA 24416	S44	1	540-291-3800	EXT 217
WILLOW HILL SUPPLY, LLC	4707 ROCKWELL ROAD	WINCHESTER, KY 40391	W33	1	859-355-5244	859-355-5244
IRA GREEN (TEXTILES)	117 GEORGIA AVE	PROVIDENCE, RI 02905	G23	1	401-467-4770	

### CODES USED TO INDICATE TYPE OF MANUFACTURER

1 TEXTILE ALL

1a - SSI      1b - Badges      1c - Grade      1d - Ribbon      1e - Tapes